

# MDB941WP-DroneCAN 28V General Specification.

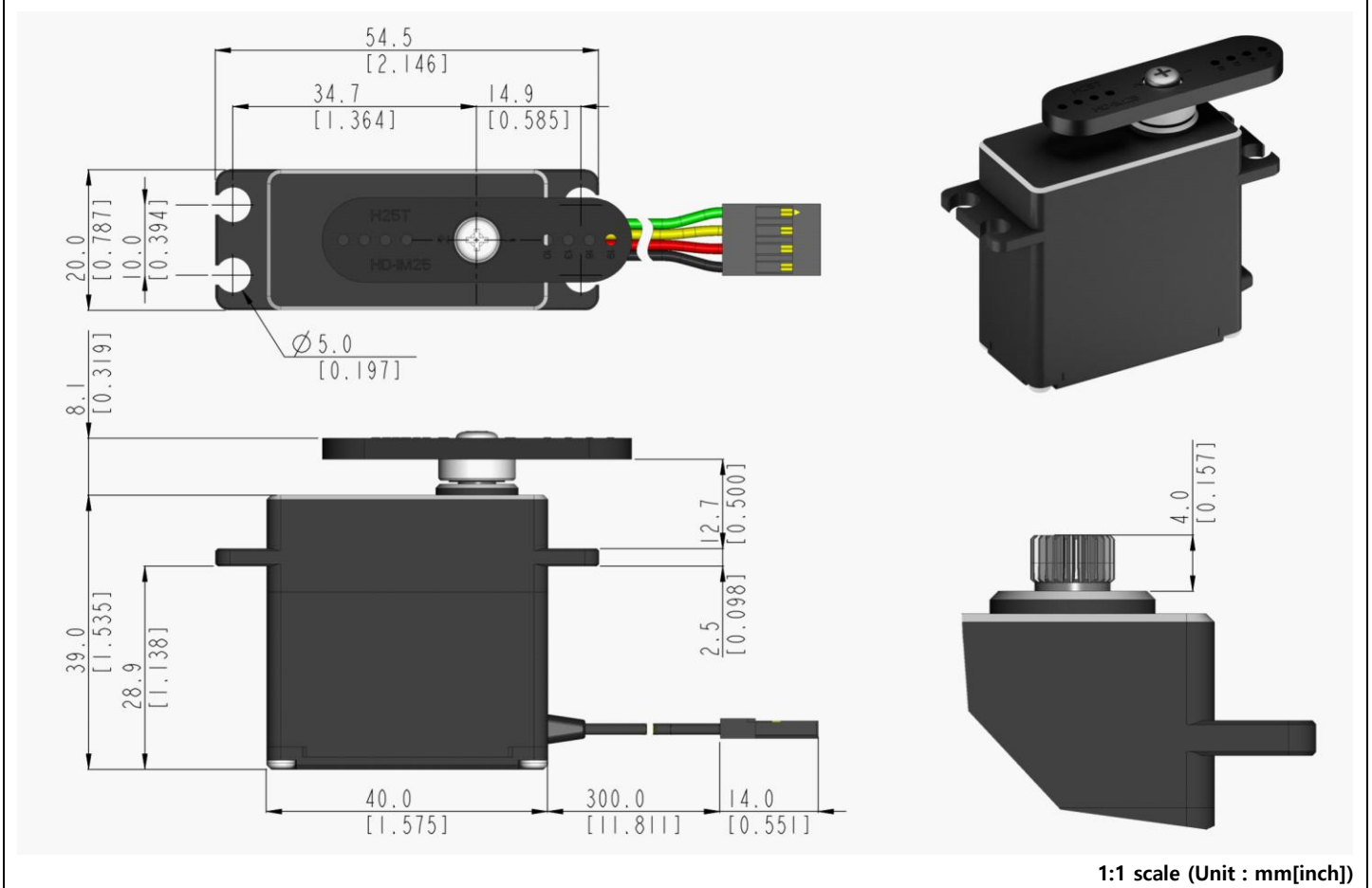

Control System	DroneCAN (UAVCAN v0)			-
Position Sensor Type	Contactless Magnetic Encoder			-
Motor Type	BLDC			At the Max voltage, it is recommended to be used only for a short time duration.
Operating Voltage Range	8.0 ~ 32.0V			
Voltage	12.0V	24.0V	28.0V	At 25°C(±10%), 45%RH(±10%) <u>measurement environment</u>
No Load Speed	0.075sec/60°	0.075sec/60°	0.075sec/60°	
Stall Torque	30.0kgf-cm (416.62oz-in)	35.0kgf-cm (486.06oz-in)	35.0kgf-cm (486.06oz-in)	
Peak Efficiency Torque	6.0kgf-cm (83.32oz-in)	7.0kgf-cm (97.21oz-in)	7.0kgf-cm (97.21oz-in)	
Standing Current	20mA	12mA	12mA	
No Load Running Current	500mA	300mA	200mA	
Stall Current	6,700mA	3,400mA	3,000mA	
Deadband	n/a	n/a	n/a	
Operating Travel	Servo Mode : ±60°(Default), ±150°(Programmable)			F/W v1.5 or Higher version
Continuous Rotation	n/a			-
Operating Temperature Range	-20°C ~ +60°C (-4°F ~ +140°F)			-
Storage Temperature Range	-30°C ~ +80°C (-22°F ~ +176°F)			-
Connector Wire Length	300mm (11.811inch)			
Connector Wire Gauge	20AWG			
Dimensions	40.0mm x 20.0mm x 39.0mm (1.575inch x 0.787inch x 1.535inch)			General Tolerance ±0.1mm
Weight	91.7g (3.235oz)			Excluding the weight of Horn
Bearing Type	2 Ball Bearing			-
Case Material	Aluminum Alloy			-
Gear Material	5 Hardened Steel Gears			-
Gear Train Backlash	Max 0.5°			-
Horn Gear Spline	25T(Ø6)			-
IP-Rating	IP67			-
Servo Amplifier Type	32bit programmable Digital			-



- This product should not be used directly on the human body for medical purposes.
- This product should not be used for war weapons.
- All specifications are subject to change without notice.
- Be careful as strong magnetic fields may cause malfunction of the product.

