

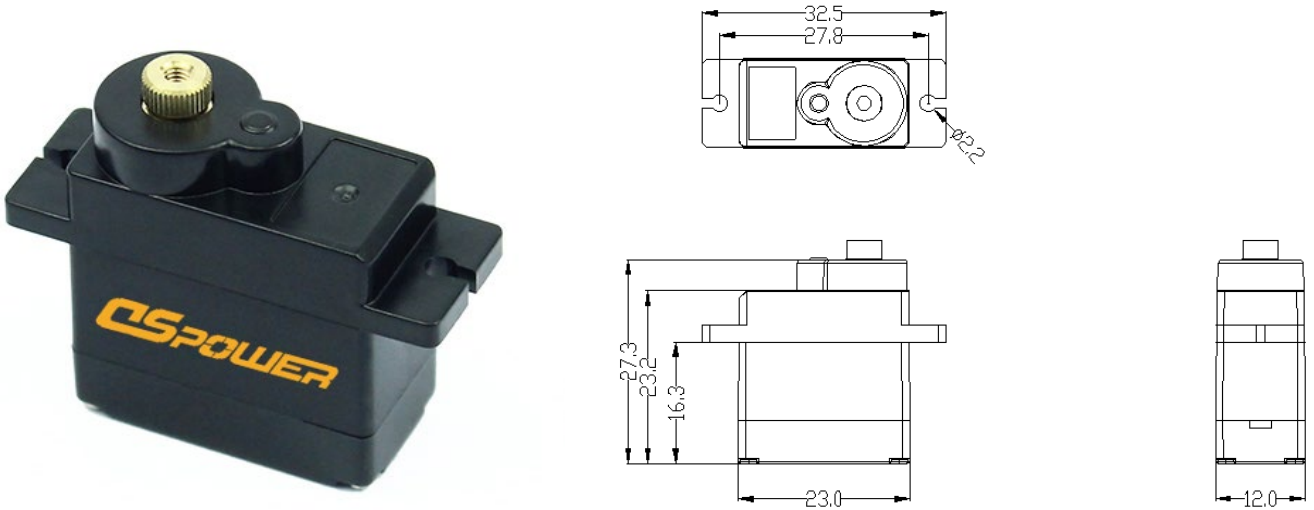

	Item	Specification	Remarks	
1	Operating Voltage 工作电压	4.8V -6VDC		
2	Standby Current 静态电流	≤10 mA		
3	Consumption Current* (No Load) 空载工作电流	4.8V	≅ 80mA	
		6V	≅ 90mA	
4	Stall Current 堵转电流	4.8V	≅ 1.2 A	
		6V	≅ 1.4A	
5	Rated Torque 额定力矩	4.8V	≥1.1 kgf.cm	
		6V	≥1.3 kgf.cm	
6	Max. Torque* 最大扭矩	4.8V	≥1.8kgf.cm	
		6V	≥2.2kgf.cm	
7	No Load Speed* 空载速度	4.8V	≅ 0.17sec/60	
		6V	≅ 0.15sec/60	
8	Rotating Direction 旋转方向	CW (1000→2000us) 逆时针转, 即正向		
9	Pulse Width Range 脉冲宽度范围	700~2300us		
10	Neutral Position 中位	1500us		
11	Operating Travel Angle 操作角度	90° ±10° (1000~2000 us)		
12	Max. Operating Travel Angle 最大可操作角度	180°±10° (500~2500us)		
13	Mechanical Limit Angle 机械极限角度	210°		
14	Left & Right Travelling Angle Deviation 左右角度差	≤ 7		
15	Centering deviation 回中差	≤ 1°		
16	Back Lash* 虚位	≤ 1°		
17	Dead Band Width 死区宽度	≤ 7 us		
18	Operating Temperature Range 工作温度	-10℃ ~ +50℃		
19	Storage Temperature Range 储存温度	-20℃~+60℃		
20	Operating Humidity Range 工作湿度	≤ 90%RH		
21	Storage Humidity Range 储存湿度	≤ 90%RH		
22	Weight 重量	13.5± 0.5g		
23	Case Material 外壳材质	ABS		
24	Gear Set Material 齿轮材质	Metal 金属齿轮		
25	Reduction ratio 减速比	1/324		
26	Motor Type 马达类型	Core motor 铁芯马达		
27	VR Parameter 电位器参数	Type 类型	Carbon-Film Potentiometer	
		Angle 角度	210°	
		Life 寿命	100 0000Cycles Min	
28	Cable 电缆	Material 材质	Φ1.08,19 芯 PVC	
		Length 长度	325±5mm (外露不含插头)	
29	Horn Gear Spline 摇臂齿数	40T/Φ4.85mm		
30	Horn Gear Type 摇臂类型	见附图		
31	Rocker Arm Screw 摇臂螺丝	PM2.0x5mm 镀镍		
32	Connector 连接器	Type 类型	JR/3Pin/黑红白/2.54mm	
		Pin Assignment 引脚定义	1 黑色 GND	
			2 红色 Vcc	
3 白色 Signal / PWM				
33	Communication Interface 通信协议	PWM	Signal Voltage: V	HIGH : Min.2.0V , Max. Vcc LOW : Min,0.0V , Max.0.45V
			Frame Rate: T	3.0 ~ 30ms (Default 20ms)
			Left/Center/Right: Td	2500/1500/500us
			Resolution	-
				
34	Amplifier Type 放大器类型	Digital		



Outside Dimension: (Unit: mm)



Picture 1-1

Accessories:



Picture 1-2

Electrical Schematic Diagram :

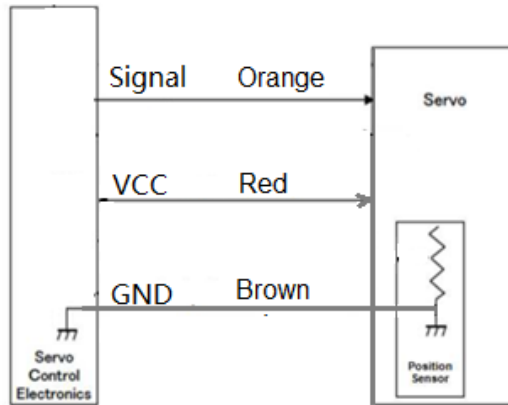

Picture 1-2

Remarks:

\* At 23±5°C (Initial Performance Data)

(抽样计划Sample Plan:

外观Appearance: MIL-STD-105E AQL II (MA=0.65/MI=1.0)

尺寸及功能Dimension and Function: MIL-STD-105E AQL I (MA=0.65/MI=1.0))