

D1005SGT General Specification.

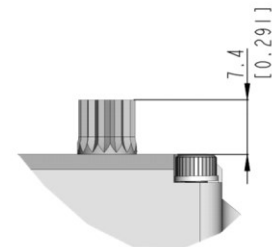

Control System	PWM/TTL(Half Duplex)		-
Position Sensor Type	Contact Analog Potentiometer		-
Motor Type	Cored Carbon Brush		At the Max voltage, it is recommended to be used only for a short time duration.
Operating Voltage Range	Motor : 9.0 ~ 16.8V, Signal : 3.5 ~ 8.4V		
Voltage	-	11.1V	14.8V
No Load Speed	-	0.26sec/60°	0.19sec/60°
Stall Torque	-	84.0kgf-cm (1,166.54oz-in)	110.0kgf-cm (1,527.61oz-in)
Peak Efficiency Torque	-	16.8kgf-cm (233.31oz-in)	22.0kgf-cm (305.52oz-in)
Standing Current	-	30mA	30mA
No Load Running Current	-	750mA	950mA
Stall Current	-	5,500mA	6,500mA
Deadband	-	2μs	2μs
Operating Travel	Default: ±60°, Programmable: Max 175° / Pulse Width: 900~2100μs(Center:1500μs)		
Continuous Rotation	n/a		-
Operating Temperature Range	-20°C ~ +60°C (-4°F ~+140°F)		-
Storage Temperature Range	-30°C ~ +80°C (-22°F ~+176°F)		-
Connector Wire Length	250mm (9.843inch)		
Connector Wire Gauge	Motor : 18AWG, Signal : 20AWG		
Dimensions	64.0mm x 33.0mm x 73.0mm (2.520inch x 1.299inch x 2.874inch)		General Tolerance ±0.1mm
Weight	310.0g (10.935oz)		Excluding the weight of Horn
Bearing Type	2 Ball Bearing		-
Case Material	Aluminum Alloy		-
Gear Material	1 Metal-Plastic & 3 Steel Gears		-
Gear Train Backlash	Max 0.5°		-
Horn Gear Spline	15T(Ø8.0)		-
IP-Rating	IP54		-
Servo Amplifier Type	32bit programmable Digital		-

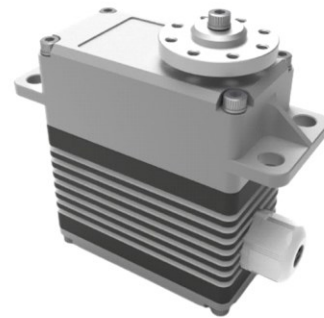
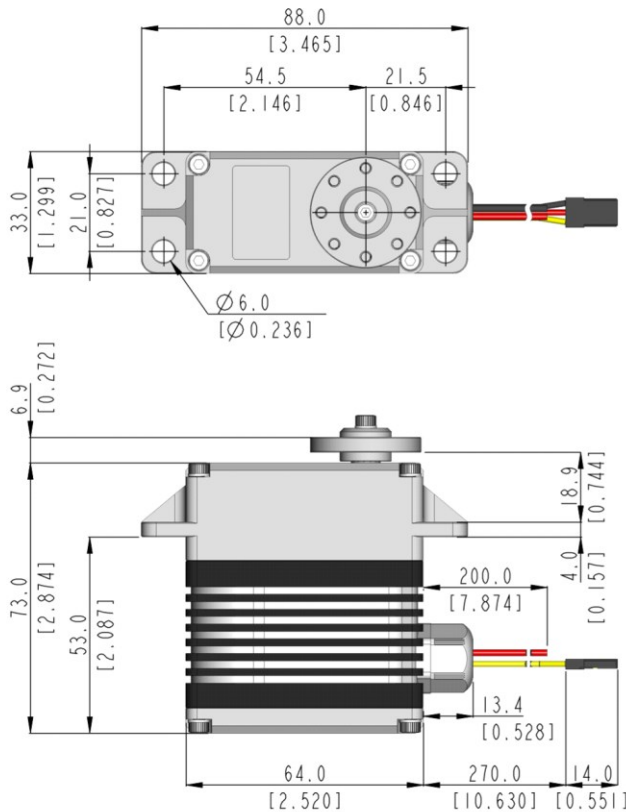

1:2 scale (Unit : mm[inch])

- This product should not be used directly on the human body for medical purposes.
- This product should not be used for war weapons.
- All specifications are subject to change without notice.

