

DB950SW General Specification.

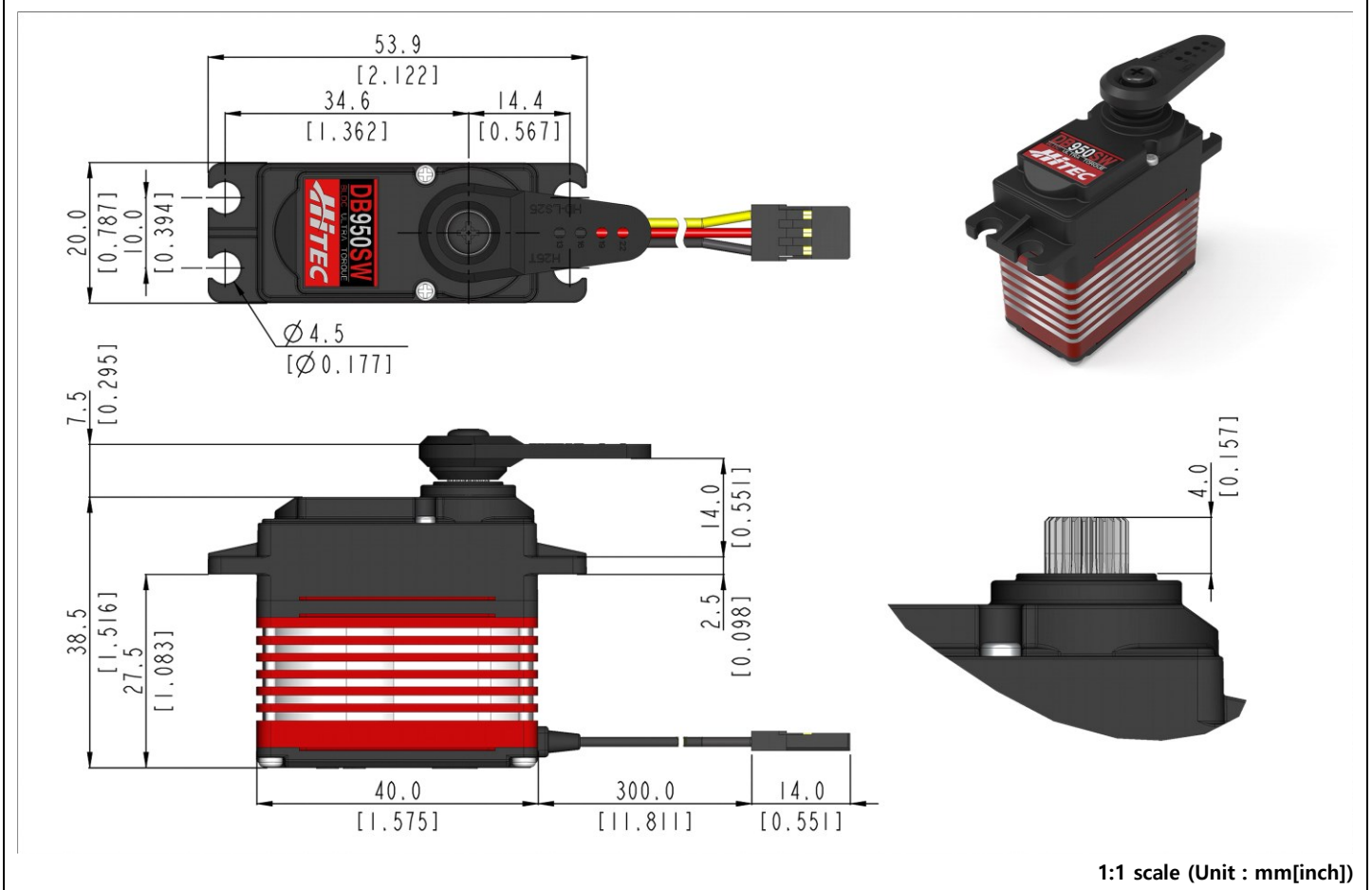

Control System	PWM/TTL(Half Duplex)			-
Position Sensor Type	Contact Analog Potentiometer			-
Motor Type	BLDC			At the Max voltage, it is recommended to be used only for a short time duration.
Operating Voltage Range	4.0 ~ 8.4V			
Voltage	4.8V	6.0V	7.4V	At 25°C(±10%), 45%RH(±10%) <u>measurement environment</u>
No Load Speed	0.23sec/60°	0.18sec/60°	0.14sec/60°	
Stall Torque	35.0kgf-cm (486.06oz-in)	40.0kgf-cm (555.5 oz-in)	40.0kgf-cm (555.5 oz-in)	
Peak Efficiency Torque	7.0kgf-cm (97.21oz-in)	8.0kgf-cm (111.1 oz-in)	8.0kgf-cm (111.1 oz-in)	
Standing Current	35mA	35mA	35mA	
No Load Running Current	350mA	350mA	350mA	
Stall Current	5,000mA	5,000mA	4,200mA	
Deadband	1μs	1μs	1μs	
Operating Travel	Default: ±60°, Programmable: Max 175° / Pulse Width: 900~2100μs(Center:1500μs)			-
Continuous Rotation	n/a			-
Operating Temperature Range	-20°C ~ +60°C (-4°F ~ +140°F)			-
Storage Temperature Range	-30°C ~ +80°C (-22°F ~ +176°F)			-
Connector Wire Length	300mm (11.811inch)			 <ul style="list-style-type: none"> 1. SIGNAL 2. VCC 3. GND
Connector Wire Gauge	20AWG			
Dimensions	40.0mm x 20.0mm x 38.5mm (1.575inch x 0.787inch x 1.516inch)			General Tolerance ±0.1mm
Weight	68.0g (2.399oz)			Excluding the weight of Horn
Bearing Type	2 Ball Bearing			-
Case Material	Engineering Plastic & Aluminum Heat Sink			-
Gear Material	1 Metal-Plastic & 3 Hardened Steel Gears			-
Gear Train Backlash	Max 0.5°			-
Horn Gear Spline	25T(Ø6)			-
IP-Rating	IP54			-
Servo Amplifier Type	32bit Programmable Digital			-



- This product should not be used directly on the human body for medical purposes.
- This product should not be used for war weapons.
- All specifications are subject to change without notice.

