

HS-5086WP General Specification.

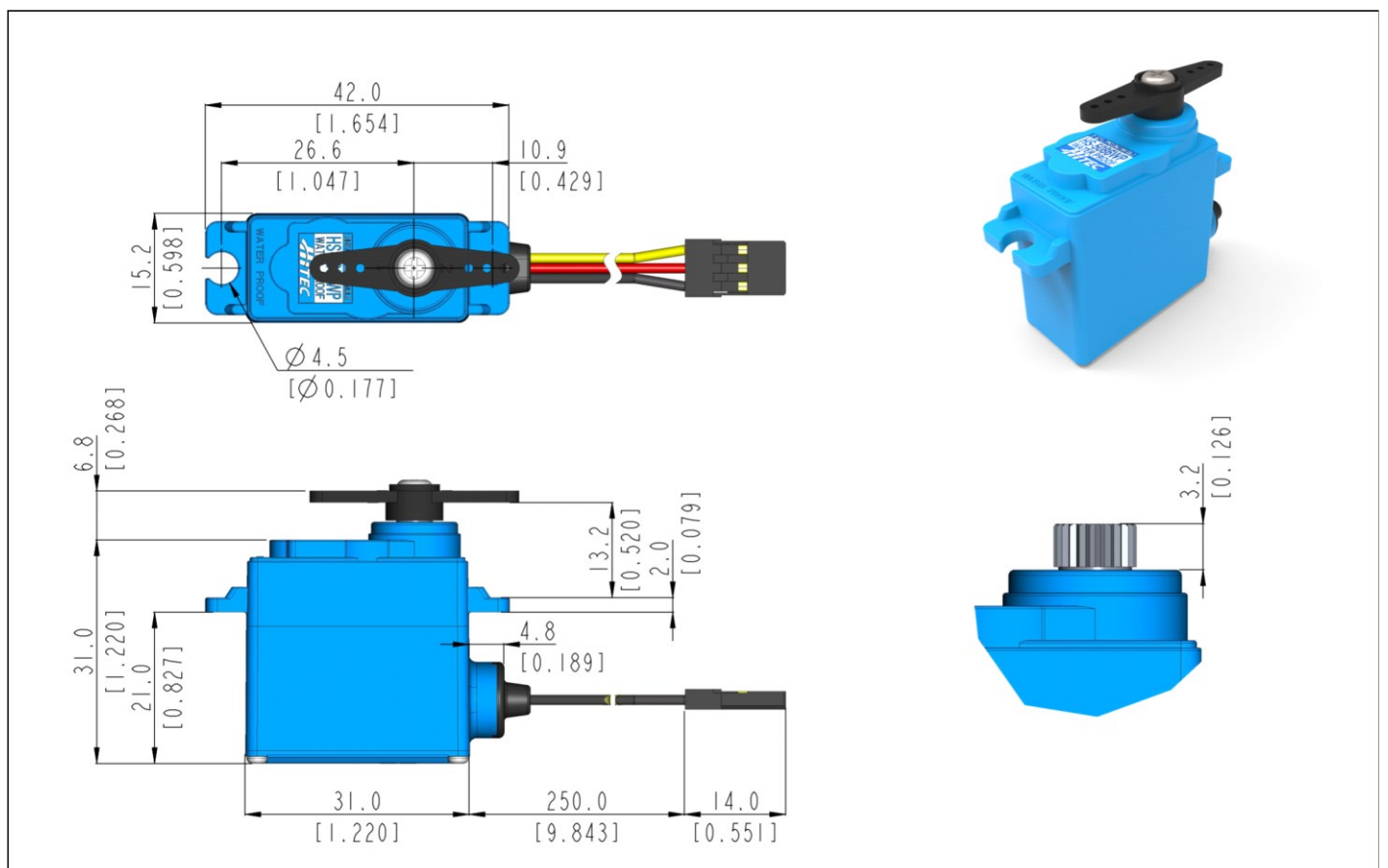

Control System	PWM			-
Position Sensor Type	Contact Analog Potentiometer			-
Motor Type	Cored Metal Brush			At the Max voltage, it is recommended to be used only for a short time duration.
Operating Voltage Range	3.5 ~ 8.4V			
Voltage	4.8V	6.0V	-	At 25°C(±10%), 45%RH(±10%) <u>measurement environment</u>
No Load Speed	0.18sec/60°	0.15sec/60°	-	
Stall Torque	3.0kgf-cm (41.7 oz-in)	3.6kgf-cm (50.0 oz-in)	-	
Peak Efficiency Torque	0.6kgf-cm (8.3 oz-in)	0.7kgf-cm (9.7 oz-in)	-	
Standing Current	3mA	3mA	-	
No Load Running Current	160mA	180mA	-	
Stall Current	1,100mA	1,400mA	-	
Deadband	2μs	2μs	-	
Operating Travel	Default: ±60°, Programmable: Max 175° / Pulse Width: 900~2100μs(Center:1500μs)			
Continuous Rotation	n/a			
Operating Temperature Range	-20°C ~ +60°C (-4°F ~+140°F)			-
Storage Temperature Range	-30°C ~ +80°C (-22°F ~+176°F)			-
Connector Wire Length	250mm (9.843inch)			 <ul style="list-style-type: none"> 1. SIGNAL 2. VCC 3. GND
Connector Wire Gauge	24AWG			
Dimensions	31.0mm x 15.2mm x 31.0mm (1.220inch x 0.598inch x 1.220inch)			General Tolerance ±0.1mm
Weight	28.5g (1.005oz)			Excluding the weight of Horn
Bearing Type	2 Ball Bearing			-
Case Material	Engineering Plastic			-
Gear Material	5 Metal Gears			-
Gear Train Backlash	Max 0.5°			-
Horn Gear Spline	24T(Ø6)			-
IP-Rating	IP67			-
Servo Amplifier Type	8bit Programmable Digital			-



1:1 scale (Unit : mm[inch])

- This product should not be used directly on the human body for medical purposes.
- This product should not be used for war weapons.
- All specifications are subject to change without notice.

