

HSR-1425CR General Specification.

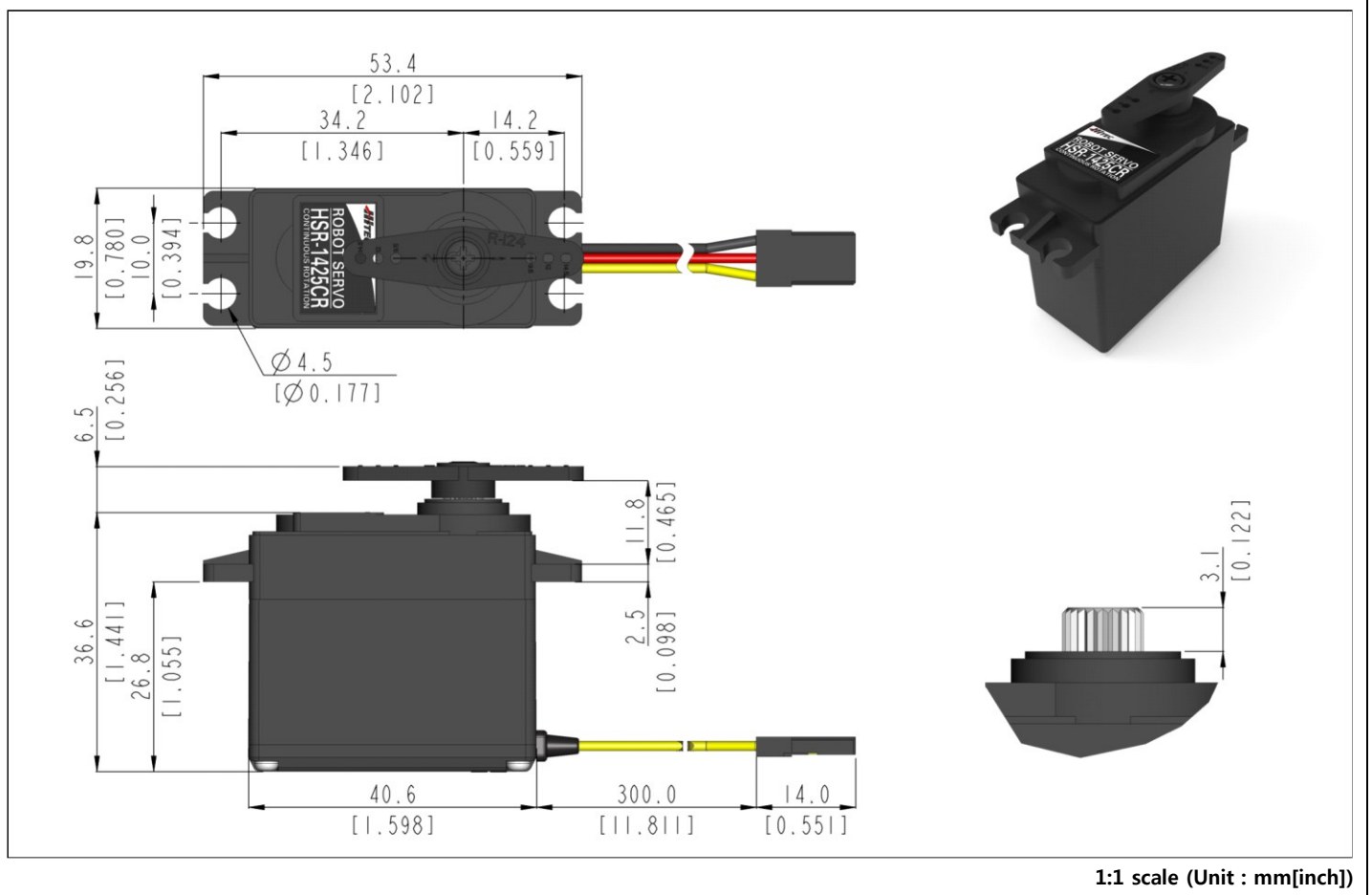

Control System	PWM			-
Position Sensor Type	-			-
Motor Type	Cored Metal Brush			At the Max voltage, it is recommended to be used only for a short time duration.
Operating Voltage Range	3.5 ~ 8.4V			
Voltage	4.8V	-	-	At 25°C(±10%), 45%RH(±10%) <u>measurement environment</u>
No Load Speed	43.4RPM	-	-	
Stall Torque	2.8kgf·cm (38.9 oz-in)	-	-	
Peak Efficiency Torque	0.6kgf·cm (8.3 oz-in)	-	-	
Standing Current	8mA	-	-	
No Load Running Current	150mA	-	-	
Stall Current	640mA	-	-	
Deadband	-	-	-	
Operating Travel	Default: Continuous Rotation / Pulse Width: 900~2100µs(Center:1500µs)			
Continuous Rotation	Able			-
Operating Temperature Range	-20°C ~ +60°C (-4°F ~ +140°F)			-
Storage Temperature Range	-30°C ~ +80°C (-22°F ~ +176°F)			-
Connector Wire Length	300mm (11.811inch)			
Connector Wire Gauge	26AWG			
Dimensions	40.6mm x 19.8mm x 36.6mm (1.598inch x 0.780inch x 1.441inch)			General Tolerance ±0.1mm
Weight	41.7g (1.471oz)			Excluding the weight of Horn
Bearing Type	2 Ball Bearing			-
Case Material	Engineering Plastic			-
Gear Material	4 Resin Gears			-
Gear Train Backlash	Max 0.5°			-
Horn Gear Spline	24T(Ø6)			-
IP-Rating	IP4X			-
Servo Amplifier Type	Analog Contorller			-



- This product should not be used directly on the human body for medical purposes.
- This product should not be used for war weapons.
- All specifications are subject to change without notice.

